

SCM5B48

Accelerometer Input Module



Description

The SCM5B48 provides excitation to piezoelectric sensors with built-in microelectronic amplifiers, commonly known as ICP®* or IEPE* or LIVM* sensors. The module provides a constant current excitation to the sensor, then isolates, filters, and amplifies the sensor output, yielding a high-level analog voltage output. The excitation current, signal gain, and filter high-pass and low-pass cutoff frequencies are field-configurable through a set of slide switches.

Six poles of signal filtering in the SCM5B48 module result in greater than 100dB of normal-mode rejection for signal frequencies above the cutoff frequency. One pole of filtering is on the field side of the isolation barrier for anti-aliasing purposes and the remaining five-pole programmable Bessel filter is located on the system side. High-pass filtering is achieved through a second order passive filter, located on the field side. If desired, the output switch can be turned on continuously by simply connecting pin 22, the Read-Enable pin, to I/O Common, pin 19.

The SCM5B48 offers the option of setting the constant current source for sensor excitation to common values of 4mA or 9mA with a compliance voltage of 24VDC. Programmable gains of 1, 10 and 100 are selectable and the module offers a ±10V output. The required supply level is +5VDC, ± 5%.

To ensure protection of expensive data acquisition equipment, the SCM5B48 module signal inputs and sensor excitation outputs are protected against accidental connection of voltages up to 240Vrms.

► Features

- Interfaces to ICP®* or IEPE* or LIVM* sensors
- ±10V Output Range
- 1500Vrms Transformer Isolation
- ANSI/IEEE C37.90.1 Transient Protection
- Input Protection to 240Vrms Continuous
- 1, 10, and 100 Programmable Gain
- 2.5, 5, 10 and 20kHz Programmable LP Filter
- 0.2 and 10 Hz Programmable HP Filter
- 4mA or 9mA Programmable Current Excitation
- ±0.2% Accuracy
- ±0.01% Linearity
- Low Drift with Ambient Temperature
- -40°C to +85°C Operating Temperature Range
- CE Compliant, CSA and FM Approvals Pending
- Mix and Match Module Types on Backpanel

*ICP is a registered trademark of PCB Group Inc.
 *IEPE is Integrated Electronic Piezo-Electric
 *LIVM is Low Impedance Voltage Mode

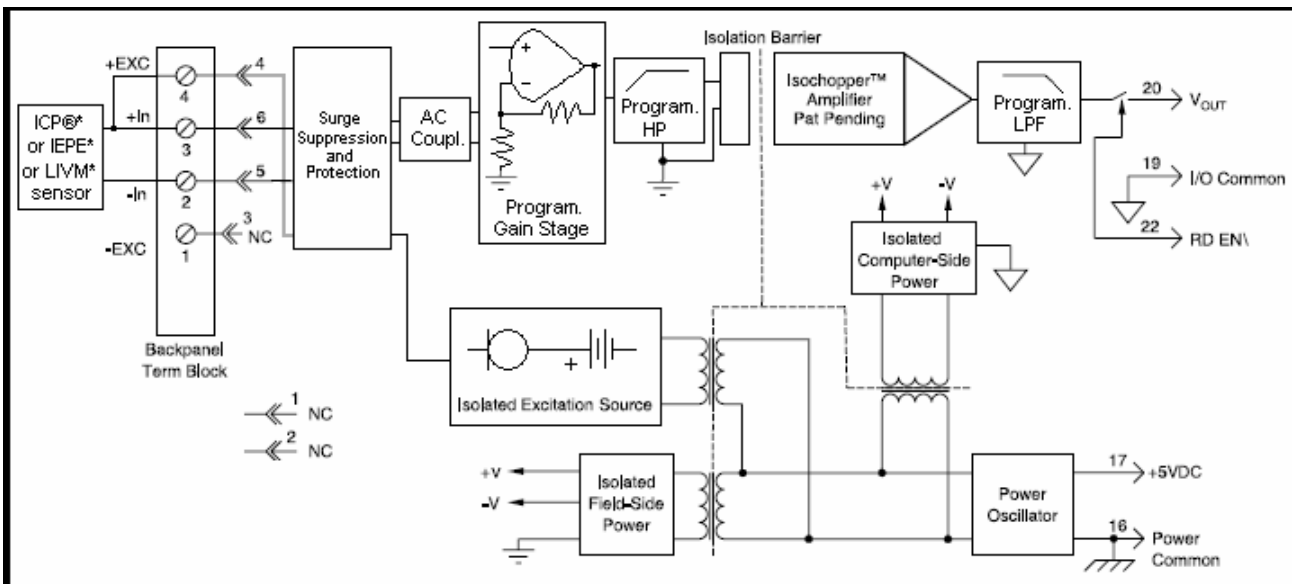

Fig.1: SCM5B48 Block Diagram